

**Tate Monroe Water  
Assn., Inc.**

**Address**

**2599 State Route 232  
New Richmond, Ohio 45157**

***CUSTOMER  
REGULATIONS AND  
GUIDELINES***

**AN EQUAL OPPORTUNITY EMPLOYER**

**REVISED: February 2024**

**T**

**M**

**W**

**A**

# TMWA VALVE REQUIREMENTS

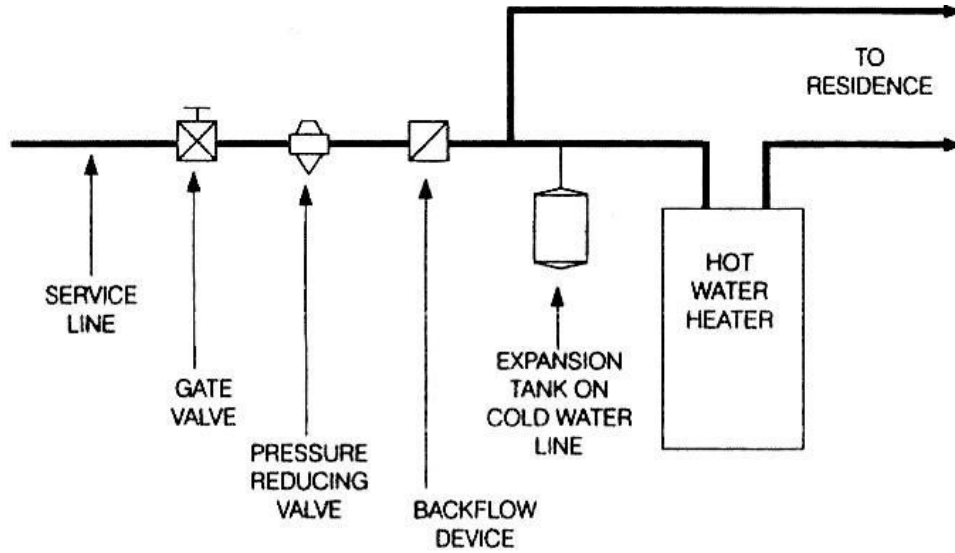

## WATER LEAKS WHO'S RESPONSIBLE

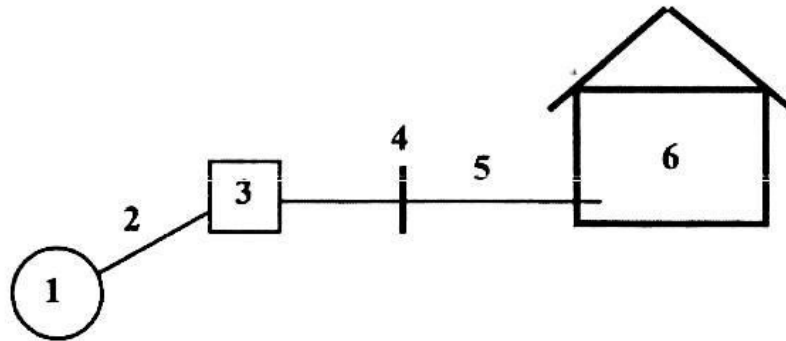

### TMWA RESPONSIBILITY

1. LEAK IN WATER MAIN
2. LEAK IN TMWA SERVICE LINE
3. LEAK IN METER VAULT

### CUSTOMER RESPONSIBILITY

4. LEAK AT PIG TAIL
5. LEAK IN SERVICE LINE TO RESIDENCE
6. LEAK INSIDE RESIDENCE

<b>I.</b>	<b>Definitions .....</b>	<b>1</b>
<b>II.</b>	<b>Membership.....</b>	<b>1</b>
<b>III.</b>	<b>Association Information.....</b>	<b>2</b>
<b>IV.</b>	<b>Membership Final Approval.....</b>	<b>3</b>
<b>V.</b>	<b>Membership and Delinquency .....</b>	<b>3</b>
<b>VI.</b>	<b>Violation of Rules and Regulations.....</b>	<b>3</b>
<b>VII.</b>	<b>Payment Responsibility.....</b>	<b>3</b>
<b>VIII.</b>	<b>Initial or Minimum Charges.....</b>	<b>4</b>
<b>IX.</b>	<b>Meter Location .....</b>	<b>5</b>
<b>X.</b>	<b>Association’s Liability.....</b>	<b>6</b>
<b>XI.</b>	<b>Member’s Responsibilities.....</b>	<b>7</b>
<b>XII.</b>	<b>Extensions to Mains and Services .....</b>	<b>8</b>
<b>XIII.</b>	<b>Access to Premises.....</b>	<b>8</b>
<b>XIV.</b>	<b>Change of Occupancy .....</b>	<b>9</b>
<b>XV.</b>	<b>Meter Reading-Billing-Collection.....</b>	<b>9</b>
<b>XVI.</b>	<b>Suspension of Service .....</b>	<b>10</b>
<b>XVII.</b>	<b>Complaints-Adjustments.....</b>	<b>11</b>
<b>XVIII.</b>	<b>Abridgement or Modification of Rules .....</b>	<b>11</b>
<b>XIX.</b>	<b>Fire Protection .....</b>	<b>12</b>

## **Introduction**

Tate Monroe Water Association, Inc. (“TMWA”) is an Ohio non-profit corporation composed of members who purchase potable water from the Association. TMWA is governed by a Board of Trustees, which has adopted rules, regulations, and resolutions for the governance and operation of the Association. The following customer regulations and guidelines set forth the Association’s expectations and requirements for members and applicants for membership in the Association and the Association’s obligations to its members with respect to the delivery of services. However, they do not supersede the rules, regulations, and resolutions adopted by the Association’s Board of Trustees. In the event of any conflict or inconsistency between these customer regulations and guidelines and the Association’s rules, regulations, and resolutions, the rules, regulations, and resolutions adopted by the Board of Trustees will control. The Board of Trustees’ interpretation of the Association’s rules, regulations, and resolutions is final and binding upon all members and applicants for membership.

This edition of the Customer Regulations and Guidelines (February 2024) supersedes all previous editions, and is subject to change by the Board of Trustees.

### **I. Definitions**

Association means Tate Monroe Water Assn., Inc. Member is synonymous with customer or consumer and is an individual, company, corporation, etc. that has met and maintained all Association requirements for membership.

### **II. Membership**

Application: Membership application is a process containing:

- A. Completion of a Water Availability questionnaire.
- B. If water is deemed available by the Association Distribution Operation Manager, the following must be completed:
  - 1. Agreement to complete all requirements to make water available.
  - 2. Water User Agreement.
  - 3. An easement with survey description of the property where the service is to be located. Even if a main exists, an easement is required and the applicant agrees to give the Association the right to upgrade when desired. If the property has a “registered” deed, the applicant must declare this and provide the actual deed to the property. (Copies of a registered deed will not be accepted by the

Clermont County Recorder's Office). In the event a property owner refuses to give the Association an easement for installation of a water line and causes the Association to use the public right of way, private easement on opposite side of the road or public right of way on the opposite side of the road and later the property owner decides to take water, he will be required to pay the actual cost incurred by the Association of installing the line in an alternate location plus the normal tap fee, or two times the normal tap fee whichever is greater.

4. Appropriate Tenant and/or Land Contract forms.
  5. Payment of the current tap fee and any other papers, agreements, etc. associated with payment of the tap fee. The tap fee is considered a "capacity charge" and is used to set the meter and upgrade the system.
  6. The Association will not refund tap fees to entities when the fee was collected as a part of those tap fees promised and paid by potential customers to induce the Association to construct a new waterline where none had existed since such fees are a part of construction estimation, policy qualification, and cost analysis in determining if such installation is physically and economically feasible.
  7. Any other forms, agreements, etc. required by the Association.
- C. If the property has a reimbursement recorded against it, that amount must be paid with the connection fee before service can be established.

### **III. Association Information**

The following items will be provided by the Association to the applicant:

1. Customer Regulations and Guidelines Booklet.
2. Requirements for installation.
3. A list of current Association water user rates and other charges.
4. A flag to mark the meter location within ten (10) to fifteen (15) feet of the driveway and adjacent to the water main or as close as is possible to the water main. This location will be inspected by an Association employee and is subject to relocation.

#### **IV. Membership Final Approval**

Final membership approval may be granted only by the Association's Board of Trustees after all requirements are fulfilled. The Board of Trustees reserves the right to deny, terminate, or refuse to reinstate membership, subject to the Association's Code of Regulations.

#### **V. Membership Termination and Delinquency:**

Membership may be terminated for cause by a vote of a majority of the trustees, though not less than a quorum. Cause includes, but is not limited to, a member's failure to comply with the Association's Code of Regulations, Customer Regulations, or resolutions and policies adopted by the Board of Trustees; a member's dishonesty or misrepresentation with respect to the member's affairs concerning the Association; a member's damage or destruction of the Association's property or failure or refusal to pay for such damage and destruction; theft of water from the Association; or failure to pay water bills to the Association when due for a period of six (6) months. No membership shall be terminated for cause unless written notice has been provided to the member at the member's address on file with the Association and the member has had an opportunity to appear and present whatever defense and information the member desires to present to the Board of Trustees at a regular meeting of the Board of Trustees or a special meeting called for that purpose, prior to such vote being taken. The decision of the Board of Trustees with respect to the termination of a member's membership shall be final. The member shall not thereafter be entitled to receive any refund of amounts paid to the Association, but shall be obligated to pay all remaining amounts due the Association. A terminated member shall not be entitled to re-apply for membership in the Association for a period one (1) year after the termination of membership for cause, and may thereafter re-apply for membership only by letter submitted to the Board of Trustees. The Board of Trustees, by majority vote, though not less than a quorum, shall determine in its sole discretion whether such former member shall be readmitted to membership in the Association.

#### **VI. Violation of Rules, Regulations, and Resolutions:**

**VII.** Violation of the Association's rules, regulations or resolutions or delinquency in payment may result in loss of membership, removal of the meter, and disconnection of service. The regular mailing of delinquency notices shall be deemed adequate notification that water service may be discontinued. If an account is delinquent and has been delinquent for 6 months or more, the service may be removed after notification of the member wherein a date for the member's response is specified. Once removed, the service may only be re-established after the current dead-tap fee is paid, the re-establishment of service is approved by the Board of Trustees, and delinquent amounts have been paid in full unless membership has been terminated by the Board of Trustees.

#### **VIII. Payment Responsibility**

The individual in whose name the membership and Water User's Agreement are held shall be responsible for payment of all bills incurred in connection with all services rendered. In the event a grantee, tenant, lessee or contract purchaser receives an outstanding bill for a specific location, before any reinstallation of service can be made at the location or any membership granted to the landowner at any other location, all delinquent and unpaid bills must be paid. Service may be denied to a current or potential member at any properties owned by the member for any outstanding water bill at any property owned by or registered to the member.

## **IX. Initial or Minimum Charges**

Initial or minimum charges are used by the Association to cover the construction cost of supply lines, plant facilities, storage and other appurtenances, as well as upgrading the system. The following guidelines will be used relative to these charges:

1. The minimum monthly fee as set in the rate schedule is payable regardless of whether water is used or there is a meter in the vault during the month.
2. The current tap fee (capacity charge) is made for each new meter installation. A meter setting may be moved from one location to another on the same property at the member's request as long as the new location is consistent with the Association's rules, regulations, and resolutions. The cost for the relocation shall be the responsibility of the member and is 1/2 of the established tap fee or the actual cost whichever is greater.
3. Water furnished for a given location, lot or farmstead shall be used at that location, lot or farmstead only. Each member's service must be separately metered at a single delivery and metering point. All commercial use, including storerooms and stalls, shall be metered separately from any residential use, and unless there is a residence and one (1) commercial user in the same building.
4. Any tax, duty, charge, etc. imposed on the Association by the county, state, or federal government or any political subdivision thereof shall be added to the member's monthly bill.
5. If an owner of residential housing desires to install an interior sprinkler system for fire protection and a meter size greater than 5/8 inches but less than or equal to 2 inches is required, the residential minimum use charge shall be based on the one-inch meter rates.

## **X. Meter Location**

See "Tate Monroe Safety and Health Standards for Connection to Public Water"

- A. The Association will install, maintain, and operate a main distribution line(s) from the source of water supply and service line(s) from the main distribution line(s) to the property line and/or on the granted easement of each member of the Association at which points, designated as delivery points, meters are purchased, installed, owned and maintained by the Association. The cost of the service line(s) from the main distribution line(s) of the Association to the meter placement of each member shall be paid by the Association, except when the total length exceeds seventy (70) feet, in which case the customer shall pay the established fee per additional foot of length. The Association will also purchase and install a cut-off valve in each service line from its main distribution line, such cut-off valve to be owned and maintained by the Association and installed on some portion of the service line owned by the Association. The Association shall have the sole and exclusive right to use the cut-off valve and to turn it on and off.
- B. Only Association personnel may open or close the valve at the meter; the member is not authorized to do so.
- C. Each member shall be entitled to one (1) service line from the Association's water system unless otherwise approved by the Board of Trustees and provided that the member shall be required to pay the prevailing tap fee for each service line. No new service line or change in existing service line may be made which will interfere with an existing service line or the delivery of water therein. Each service line shall connect



with the Association's water system at the nearest available point to the location of desired use by the member.

- D. It is the responsibility of the landowner to ensure that the meter setting is located on the member's property. If after installation the meter setting is proven to not be on the member's property, the member shall absorb the cost of relocation.
- E. Before a new connection can be made to an existing service line, the Association's water system must be of sufficient capacity to permit delivery of water through a service line at that place without interfering with the delivery of water through an existing service line. If the Association's water system is inadequate to permit the delivery of water through a service line installed at such place without interfering with the delivery of water through a service line, such service line shall not be installed.
- F. Each member is required to dig or have dug a trench and to purchase, install, and maintain such portion of the service line or lines from the end of the pigtail to the member's dwelling or other place of use on his premises at his own expense. The connection at the pigtail junction is the responsibility of the member.

#### **XI. Association's Liability**

- A. The Association does not assume the responsibility of inspecting the member's piping or apparatus and will not be responsible for failures of such piping or apparatus.
- B. The Association reserves the right to inspect and to refuse service unless the member's lines and piping are installed in such manner as to prevent cross-connections or back-flow and unless such installation is in accordance with all county and state health department regulations and the Association's rules, regulations, and resolutions.
- C. The Association shall not be liable for damage of any kind whatsoever resulting from water or use of water on the member's premises unless such damage results directly from negligence on the part of the Association. The Association shall not be responsible for any damage done by or resulting from any defects in piping, fixtures, or appliances on the member's premises. The Association shall not be responsible for negligence of third persons or forces beyond the control of the Association resulting in any interruption of service, including but not limited to weather conditions, broken or frozen lines, or acts of God.
- D. Under normal conditions, members will be notified of any scheduled interruptions of service.

## **XII. Member's Responsibilities**

- A. Piping on the member's premises must be so installed that the connections are conveniently located with respect to Association lines and mains.
- B. If the Association is called upon to provide additional meters, each place of metering will be considered as a separate individual account.
- C. The member shall provide a place of metering which is unobstructed and accessible to the Association at all times.
- D. The member shall furnish and maintain a private cut-off valve on the member's side of the meter. The Association will provide a like valve on the Association's side of the meter. In addition, the member shall install and maintain a dual check valve, a pressure reducing valve and an expansion tank on the water heater installed on the cold water inlet. The backflow prevention device required at a business or commercial establishment shall be a testable. The placement of these controls is specified in the Association's Rules for Connection to Public Water.
- E. The member's piping and apparatus shall be installed and maintained by the member at the member's expense in a safe and efficient manner and in accordance with the Association's rules, regulations, and resolutions, and in full compliance with sanitary regulations of the state and county board of health.
- F. The member shall guarantee proper protection of the Association's property placed on the member's premises and shall permit access to it only by authorized representatives of the Association.
- G. In the event that any loss or damage to the property of the Association or any accident or injury to persons on property is caused by or results from the negligence or wrongful act of the member, his agent or employees, the cost of the necessary repairs or replacement shall be paid by the member to the Association and liability otherwise resulting shall be assumed by the member. The amount of such loss or damage or the cost of repairs shall be added to the member's bill if not otherwise paid; and if not paid, service may be discontinued by the Association.
- H. Water furnished by the Association for residential use shall be used only for domestic consumption by the member. The member shall not sell water to any person or permit use by another residence, business, or commercial establishment. Consult the Association's Distribution Operations Manager to determine sufficient water quantity for irrigation, fire protection, and purposes other than domestic use.

- I. Sufficient quantity shall be determined by the Association upon review of the completed "Water Availability" questionnaire submitted by the party seeking such determination. Disregard for this rule shall be sufficient cause for refusal or discontinuance of service.

### **XIII. Extensions to Mains and Services**

- A. Ask For:
  - (1) Water Main Extension/Subdivisions Policy
  - (2) Water Main Extension Specifications
  - (3) Reimbursement Policy
- B. The Association will supply temporary service based on requirements of the Distribution Division and proper installation of backflow prevention and flow control devices.
- C. A Project Engineer, Ohio EPA, and the Association's Distribution Manager must approve all proposed main extensions.
- D. The Association will permit construction of extensions to its water lines, but the Association shall not be required to make such installations unless the member pays the entire cost of installation.
- E. All line extensions shall be made in accordance with current extension policies and Specifications for Subdivision Rules and Regulations and shall be evidenced by a contract signed by the Association and the person advancing funds for the extension. Any contract not approved by the Ohio EPA or Rural Development, if applicable, shall be considered null and void. Any addition to or upgrade of the Association's distribution system shall be deemed a "substantial change," and shall require OEPA approval. Such approval is the responsibility of the person advancing funds for the project.

### **XIV. Access to Premises**

- A. Duly authorized agents of the Association shall have access at all times to the land and buildings of the member for the purpose of installing or removing Association property, inspecting or repairing piping, reading or testing meters, or any other purpose in connection with the Association's service and facilities.
- B. Each member shall grant and convey or shall cause to be granted and conveyed to the Association a permanent easement and right-of-way across any property owned or controlled by the member wherever a permanent easement and right-of-way is necessary for the Association's water facilities and lines in order to enable the Association to maintain service to its members and upgrade service in the future.

## **XV. Change of Occupancy**

- A. Not less than one (1) week's notice must be given to the Association to discontinue service or change occupancy.
- B. The outgoing party shall be responsible for all water usage until he or she calls for a read out and termination of service.
- C. It is the responsibility of the seller/buyer or landlord/renter to coordinate this transaction with the Association.

## **XVI. Meter Reading-Billing-Collection**

- A. Meters will be read or estimated and bills rendered bi-monthly, but the Association reserves the right to vary the dates or length of period covered, temporarily or permanently if necessary or desirable.
- B. Bills for water will be computed in accordance with the Association's published rate schedule and will be based on the amount consumed or estimated for the period covered. Charges for service commence when the meter is installed or after sixty (60) days following the meter vault installation, whichever occurs first.
- C. Readings from more than one meter cannot be combined for billing. This includes meters serving the same or different premises.
- D. The NET amount on the bill is payable on or before the due date indicated on the bill. When payment for service is mailed to the Association, the postmark on the current non-delinquent remittance will be deemed the time that payment is received. Failure to receive bills or notices for water service will not relieve the member from responsibility for prompt payment.
- E. Payments on bills not received by 4:00 P.M. on the due date will be charged a 10% penalty; except that when the 10<sup>th</sup> falls on Saturday or Sunday, payments received in the drop box Monday morning, prior to 9:00 a.m. will not be charged the 10% delinquent fee.
- F. Any bill paid by check which is later dishonored by the bank on which it is drawn will cause the account to become delinquent, and must be paid in full within twenty-four hours with cash, certified check, or money order to insure continuous service. An established charge or actual bank charge, whichever is greater will be assessed for a bad check. The Association has no obligation to notify customers when bad checks are returned. Service will immediately be terminated if the Association is notified of a returned bad check.
- G. Checks that are refused by the bank on which they are written can be redeemed by the member for the amount of the check plus the current

charge for a bad check . If not redeemed, charges may be filed with the Clermont County Prosecuting Attorney's office for recovery.

## **XVII. Suspension of Service**

- A. Postmarks will not be accepted on delinquent payments generated by delinquent billing notices.
- B. Upon discontinuance of service for non-payment of bills, the Association may collect the balance in the manner provided by law for the collection of debts and may refuse service at the location in question in the future, until the debt is paid.
- C. Service discontinued for non-payment of bills will be restored only after the current bill is paid in full for each meter reconnected. The Association office closes at 4:00 PM. each weekday. See Disconnection of Service Policy on the back inside cover of this document. Delinquent accounts are subject to disconnection of service after the 25th day of the month in which bills are due.
- D. The Association reserves the right to discontinue service without notice for the following additional reasons:
  - 1. To prevent fraud or abuse.
  - 2. The member's violation of the Association's rules, regulations, or resolutions.
  - 3. Emergency repairs.
  - 4. Insufficiency of supply due to circumstances beyond the Association's control.
  - 5. Legal process or court order.
  - 6. Direction or order of public authorities.
  - 7. Strike, riot, flood, accident, or any unavoidable cause.
  - 8. Disregard or violation of backflow prevention device(s).
- E. In addition to pursuing all remedies available to the Association by law, the Association may refuse service to and terminate the membership of any member who tampers with a meter or other measuring device or other Association property.

- F. The Association regularly mails delinquency notices. Any such notice shall be deemed adequate notification for discontinuance of service to a member's property. It is the policy of the Association to discontinue service after an account is delinquent.
- G. If a meter is removed at the request of the member, a fee will be charged for both the removal and subsequent reinstallation. This fee must be paid in advance of reinstatement of service.
- H. A service fee will be charged if the Association responds to a customer call claiming that the Association's service line is leaking and it is found that the leak is on the customer's side of the meter setting. This charge will apply to all times except for the regular workday.

### **XVIII. Complaints-Adjustments**

- A. If the member believes his or her bill to be in error, he or she may present his or her claim in person or in writing to the Association's office before the bill becomes delinquent. Such claim, if made after the bill has become delinquent, shall not be effective in preventing discontinuance of service. The member may pay such bill under protest and payment shall not prejudice his or her claim.
- B. A meter will be tested at the request of the member upon payment to the Association of the applicable fee, provided that meter-tampering has not occurred. If the meter fails to register correctly or is stopped for any cause, the member shall pay an amount estimated from the record of his or her previous bills and/or other proper data. If the meter test shows the meter to be defective, by registering high according to AWWA standards, the cost of the test will be reimbursed to the member.

### **XIX. Abridgement or Modification of Rules**

- A. No promise, agreement, or representation of any employee of the Association shall be binding upon the Association except as it shall have been agreed upon in writing, signed and accepted by the authorized officers of the Association and approved by the Board of Trustees.
- B. No modification of rates or any of the rules and regulations shall be made by any agent of the Association.

**XX. Fire Protection**

See Resolution #020883 (2/8/83):

**RESOLUTION NO. 020883 - PASSED 2/8/83**

A resolution of Tate Monroe Water Association, Inc., Board of Trustees concerning volume and pressure of its water supply. BE IT RESOLVED by the Board of Trustees of Tate Monroe Water Association, Inc. that WHEREAS, Tate Monroe Water Association does have customers who have fire sprinkler systems connected to the Tate Monroe Water Association lines; and, WHEREAS, Tate Monroe Water Association, Inc. was built as a supplier of rural water service for agricultural and domestic purposes; and, WHEREAS, Tate Monroe Water Association's entire system is not designed to guarantee any customer full volume or to guarantee the consumer specific pressure or for that matter even a continuous supply of water after the normal operation of domestic usage, NOW THEREFORE, BE IT RESOLVED by the Tate Monroe Water Association, Inc. Board of Trustees as follows:

**SECTION I.** Tate Monroe Water Association, Inc. does not guarantee consumer's full volume, fixed pressure or an effective continuous supply of water as such volume and pressure and supply of water is not designed or built into the Tate Monroe Water Association, Inc. rural water system.

**SECTION II.** It is further resolved that Tate Monroe Water Association, Inc. cannot and will not be responsible for the full volume and any specific pressure or an effective continuous supply of water for the normal operation of agricultural use, domestic use, comievgial use, fire sprinkler systems and any other uses utilized by the members of the distribution system because a continuous supply of water at any given flow or pressure is subject to varying conditions which may affect the operation and maintenance of the mains, services, pumping stations, elevated storage tanks and other appurtenances of the water system.

**SECTION III.** This Resolution shall be immediate effect upon its passage and all new customers be given a copy of the Resolution and the next meeting notice shall include either a copy of this Resolution or sufficient information so that each customer will have knowledge of the adoption of this Resolution

This page left intentionally blank



## **Disconnection POLICY**

**All meters locked for non-payment will remain locked until payment is made and any payment made for a meter locked for non-payment after the regular business day (9:00 a.m. to 4:00 p.m.) shall remain locked until the next regular business day.**

**All medical reasons for continuous water service must be on file so that individual contact can be made to avoid locking said meters; however, if payment is not made by an agreed time then the meter shall be locked.**

**A minimum fine of \$250 or the actual cost of material and labor plus 15% shall be billed to customers for damage to any association equipment and/or locking devices.**

**All other association's policies relative to disconnection charges shall remain in effect.**

### **OFFICE HOURS**

**9:00 am – 4:00 pm  
Monday – Friday  
Closed Saturday and Sunday**

**Phone 734-2236**

**Payments received after 4:00 pm  
will be credited on the next  
working day**